



US Army Corps  
Of Engineers  
Wilmington District

# PUBLIC NOTICE

Issue Date: 8 April, 2015  
Comment Deadline: 8 May, 2015  
Corps Action ID Number: SAW-2006-40176-16

The Wilmington District, Corps of Engineers (Corps) received an application from the National Park Service seeking Reauthorization of a Department of the Army permit to complete an unfinished shoreline protection project associated with the Cape Lookout National Seashore in Harkers Island, Carteret County, North Carolina.

Specific plans and location information are described below and shown on the attached plans. This Public Notice and all attached plans are also available on the Wilmington District Web Site at:

<http://www.saw.usace.army.mil/Missions/RegulatoryPermitProgram.aspx>

**Applicant:** Mr. Patrick Kenney  
National Park Service  
Cape Lookout National Seashore  
131 Charles Street  
Harkers Island, North Carolina 28531

## Authority

The Corps evaluates this application and decides whether to issue, conditionally issue, or deny the proposed work pursuant to applicable procedures of the following Statutory Authorities:

- Section 404 of the Clean Water Act (33 U.S.C. 1344)
- Section 10 of the Rivers and Harbors Act of 1899 (33 U.S.C. 403)
- Section 103 of the Marine Protection, Research and Sanctuaries Act of 1972 (33 U.S.C. 1413)

## Location

Directions to Site: The National Park Service (NPS), Cape Lookout National Seashore (CLNS), Park Headquarters is located at the southeastern end of Harkers Island, Carteret County, North Carolina. The location of the project site is along the northern shoreline of the Park Headquarters property.

Project Area (acres): 0.66 (960 lf)      Nearest Town: Harkers Island  
Nearest Waterway: Core Sound      River Basin: Neuse-Pamlico  
Latitude and Longitude (Decimal Degrees): 34.687313 N, -76.527221 W

### **Existing Site Conditions**

Under a previous authorization, the majority of the originally proposed sill structure was constructed in 2008. The entire project was not able to be completed due to funding constraints, but the entire project was previously authorized by a Department of the Army permit.

The currently exposed shoreline of the NPS/CLNS Park Headquarters property has been experiencing severe and persistent erosion for many years, primarily due to the effects of wave action with occasional inundation at high tide and, to a lesser extent, wake from boat traffic. As a result, there has been significant and continuing loss of high ground property and damage to structures along the shoreline that was not initially protected in 2008. The goal of the proposed action is to effectively and economically stabilize the shoreline to prevent further erosion, while maintaining as natural a shoreline appearance as possible. Please see attached map with overall project depictions.

### **Applicant's Stated Purpose**

The purpose of the work is to provide shoreline erosion protection of the remaining 960 feet of actively eroding shoreline along the western portion of the National Park Service Harkers Island site.

### **Project Description**

The proposed project would involve the completion of a previously authorized offshore stone sill with a trapezoidal cross-section (Typical design attached). The stone would be North Carolina Department of Transportation (NCDOT) class 2 riprap, approximately 24 inches in size, laid over geotextile fabric. The sill is designed to be adjacent to submerged aquatic vegetation (SAV) beds without directly impacting any SAV beds. The sill would lie at an elevation +3' NGVD (mean high water) in water shoreward of all SAV beds, and waterward of existing emergent marsh vegetation to the extent possible. The proposed position, approximately 30 to 60 feet offshore, would allow development of additional marsh vegetation in viable portions of the shallows between sill and shoreline. Marsh grass would be planted along the water's edge in these reaches to the extent feasible. The top of the sill would be positioned approximately one foot above mean high water, and openings would be incorporated for circulation to maintain water quality, for cross-movement of aquatic organisms.

A slight deviation from the originally permitted plan is proposed to remove an existing tie-in that promote hydraulic flushing. There will also be a modification to the previously

permitted northern tie-in to accommodate current erosional conditions that have manifested since 2008.

The previously authorized and constructed impacts include bulkhead and boat ramp repair: This included the repair and replacement of existing bulkheads. Repair included excavation behind portions of the existing bulkhead to inspect and repair holes, placement of a stone filter layer and filter fabric, and construction of concrete splash protection along the top of the wall. This work also involved replacement of portions of existing bulkheads which were failing, as well as other selected portions where a new system was desired. The replacement structure is a vinyl sheet pile system that was placed just outside the existing bulkheads. The previous boat ramp was replaced with a new concrete ramp about 20' wide. The adjacent bulkhead was extended to accommodate the new ramp which was narrower than the existing one. This also included the construction of a breakwater extension at the outer opening of the basin entrance.

Construction of the proposed project permanently impacted 0.05 acres of jurisdictional wetlands. The breakwater extension footprint covered approximately 1800 square feet (0.04 acre) of bottom in open waters. The current sill footprint covers approximately 1.53 acres of bottom on the southern sill section waters, and the current request for reauthorization would cover the remaining 960 lf (0.66 acre).

### **Avoidance and Minimization**

The applicant provided the following information in support of efforts to avoid and/or minimize impacts to the aquatic environment: The sill will be constructed within the water of Core Sound adjacent to the Harkers Island National Park Service land. Avoiding all impacts to Section 404/10 is not possible since this project must be constructed in the water to alleviate shoreline erosion caused by wave action. Impacts are being minimized by avoiding existing known SAVs and peat layer outcrops surveyed prior to the construction of the previously constructed portion of the sill to the south. Minimal amounts of fill are proposed to address erosion. Removal of an existing tie-in is also proposed to minimize effects on flushing and habitat continuity.

### **Compensatory Mitigation**

The applicant did not offer a compensatory mitigation plan to offset unavoidable functional loss to the aquatic environment.

### **Essential Fish Habitat**

Pursuant to the Magnuson-Stevens Fishery Conservation and Management Act, this Public Notice initiates the Essential Fish Habitat (EFH) consultation requirements. The initial determination is that the proposed project may affect, and is likely to adversely affect EFH or associated fisheries managed by the South Atlantic or Mid Atlantic Fishery

Management Councils or the National Marine Fisheries Service. These impacts to EFH include loss of habitat at the fill site and temporary siltation plumes due to construction. The Essential Fish Habitat (EFH) consultation requirements of the Magnuson-Stevens Fishery Conservation and Management Act will be satisfied by the National Parks Service as the Lead Agency.

### Cultural Resources

Pursuant to Section 106 of the National Historic Preservation Act of 1966, Appendix C of 33 CFR Part 325, and the 2005 Revised Interim Guidance for Implementing Appendix C, the District Engineer consulted district files and records and the latest published version of the National Register of Historic Places and initially determines that:

- Should historic properties, or properties eligible for inclusion in the National Register, be present within the Corps' permit area; the proposed activity requiring the DA permit (the undertaking) is a type of activity that will have no potential to cause an effect to an historic properties.
- No historic properties, nor properties eligible for inclusion in the National Register, are present within the Corps' permit area; therefore, there will be no historic properties affected. The National Parks Service is the Lead Agency and no Corps concurrence is requested. The Corps will not make a permit decision until the Section 106 review has been concluded by the National Parks Service as the Lead Agency.
- Properties ineligible for inclusion in the National Register are present within the Corps' permit area; there will be no historic properties affected by the proposed work. The Corps subsequently requests concurrence from the SHPO (or THPO).
- Historic properties, or properties eligible for inclusion in the National Register, are present within the Corps' permit area; however, the undertaking will have no adverse effect on these historic properties. The Corps subsequently requests concurrence from the SHPO (or THPO).
- Historic properties, or properties eligible for inclusion in the National Register, are present within the Corps' permit area; moreover, the undertaking may have an adverse effect on these historic properties. The Corps subsequently initiates consultation with the SHPO (or THPO).
- The proposed work takes place in an area known to have the potential for the presence of prehistoric and historic cultural resources; however, the area has not been formally surveyed for the presence of cultural resources. No sites eligible for inclusion in the National Register of Historic Places are known to be present in the vicinity of the proposed work. Additional work may be necessary to identify and assess any historic or prehistoric resources that may be present.

The District Engineer's final eligibility and effect determination will be based upon coordination with the SHPO and/or THPO, as appropriate and required, and with full consideration given to the proposed undertaking's potential direct and indirect effects on historic properties within the Corps-identified permit area.

### **Endangered Species**

Pursuant to the Endangered Species Act of 1973, the Corps reviewed the project area, examined all information provided by the applicant and consulted the latest North Carolina Natural Heritage Database. Based on available information:

- The Corps determines that the proposed project would not affect federally listed endangered or threatened species or their formally designated critical habitat.
- The initial determination is that the proposed project may affect, but is not likely to adversely affect Federally listed endangered or threatened species or their formally designated critical habitat. The Corps will not make a permit decision until the consultation process is concluded by the National Parks Service as the Lead Agency.
- The Corps is not aware of the presence of species listed as threatened or endangered or their critical habitat formally designated pursuant to the Endangered Species Act of 1973 (ESA) within the project area. The Corps will make a final determination on the effects of the proposed project upon additional review of the project and completion of any necessary biological assessment and/or consultation with the U.S. Fish and Wildlife Service and/or National Marine Fisheries Service.

### **Other Required Authorizations**

The Corps forwards this notice and all applicable materials to the appropriate State agencies for review.

**North Carolina Division of Water Resources (NCDWR):** The Corps will generally not make a final permit decision until the NCDWR issues, denies, or waives the state Certification as required by Section 401 of the Clean Water Act (PL 92-500). The receipt of the application and this public notice, combined with the appropriate application fee, at the NCDWR Central Office in Raleigh constitutes initial receipt of an application for a 401 Certification. A waiver will be deemed to occur if the NCDWR fails to act on this request for certification within sixty days of receipt of a complete application. Additional information regarding the 401 Certification may be reviewed at the NCDWR Central Office, 401 and Buffer Permitting Unit, 512 North Salisbury Street, Raleigh, North Carolina 27604-2260. All persons desiring to make comments regarding the application for a 401 Certification should do so, in writing, by May 8, 2015 to:

NCDWR Central Office  
Attention: Ms. Karen Higgins, 401 and Buffer Permitting Unit  
(USPS mailing address): 1617 Mail Service Center, Raleigh, NC 27699-1617

Or,

(physical address): 512 North Salisbury Street, Raleigh, North Carolina 27604

**North Carolina Division of Coastal Management (NCDCM):**

- The application did not include a certification that the proposed work complies with and would be conducted in a manner that is consistent with the approved North Carolina Coastal Zone Management Program. Pursuant to 33 CFR 325.2 (b)(2) the Corps cannot issue a Department of Army (DA) permit for the proposed work until the applicant submits such a certification to the Corps and the NCDCM, and the NCDCM notifies the Corps that it concurs with the applicant's consistency certification. As the application did not include the consistency certification, the Corps requests, via this Public Notice, concurrence or objection from the NCDCM.
- Based upon all available information, the Corps determines that this application for a Department of Army (DA) permit does not involve an activity which would affect the coastal zone, which is defined by the Coastal Zone Management (CZM) Act (16 U.S.C. § 1453).

**Evaluation**

The decision whether to issue a permit will be based on an evaluation of the probable impacts including cumulative impacts of the proposed activity on the public interest. That decision will reflect the national concern for both protection and utilization of important resources. The benefit which reasonably may be expected to accrue from the proposal must be balanced against its reasonably foreseeable detriments. All factors which may be relevant to the proposal will be considered including the cumulative effects thereof; among those are conservation, economics, aesthetics, general environmental concerns, wetlands, historic properties, fish and wildlife values, flood hazards, flood plain values (in accordance with Executive Order 11988), land use, navigation, shoreline erosion and accretion, recreation, water supply and conservation, water quality, energy needs, safety, food and fiber production, mineral needs, considerations of property ownership, and, in general, the needs and welfare of the people. For activities involving the discharge of dredged or fill materials in waters of the United States, the evaluation of the impact of the activity on the public interest will include application of the Environmental Protection Agency's 404(b)(1) guidelines.

## **Commenting Information**

The Corps of Engineers is soliciting comments from the public; Federal, State and local agencies and officials, including any consolidated State Viewpoint or written position of the Governor; Indian Tribes and other interested parties in order to consider and evaluate the impacts of this proposed activity. Any comments received will be considered by the Corps of Engineers to determine whether to issue, modify, condition or deny a permit for this proposal. To make this decision, comments are used to assess impacts on endangered species, historic properties, water quality, general environmental effects and the other public interest factors listed above. Comments are used in the preparation of an Environmental Assessment (EA) and/or an Environmental Impact Statement (EIS) pursuant to the National Environmental Policy Act (NEPA). Comments are also used to determine the need for a public hearing and to determine the overall public interest of the proposed activity.

Any person may request, in writing, within the comment period specified in this notice, that a public hearing be held to consider the application. Requests for public hearings shall state, with particularity, the reasons for holding a public hearing. Requests for a public hearing shall be granted, unless the District Engineer determines that the issues raised are insubstantial or there is otherwise no valid interest to be served by a hearing.

The Corps of Engineers, Wilmington District will receive written comments pertinent to the proposed work, as outlined above, until 5pm, May 8, 2015. Comments should be submitted to Mr. Tyler Crumbley, Wilmington Regulatory Field Office, 69 Darlington Avenue, Wilmington, North Carolina 28403 , at (910) 251-4170.





- NOTES:**
1. SURVEYING AND MAPPING BY: MALKIN & CRENSHAW ENGINEERS, P.A.  
243 N. FRONT ST.  
WILMINGTON, NC 28401  
1-910-343-1048
  2. ALL ELEVATIONS ARE BASED ON NGVD 29
  3. ONE FOOT CONTOUR INTERVAL
  4. ALL COORDINATES ARE BASED ON NCGRID (NAD83)
  5. FIELD WORK PERFORMED JANUARY, 2005

**NOTE EXISTING STONE TIE-IN:**  
 THE CONTRACTOR MAY USE THE EXISTING NORTH STONE SILL TIE-IN AS TEMPORARY ACCESS FOR THE CONSTRUCTION OF THE NEW NORTH STONE SILL. THE CONTRACTOR SHALL MAINTAIN THE EXISTING NORTH STONE SILL TIE-IN TO THE EXISTING SANDWATER AND MAINTAIN THE EXISTING SANDWATER APPROXIMATELY THE EXISTING NORTH STONE SILL TIE-IN TO THE CONSTRUCTION OF THE NEW NORTH STONE SILL.

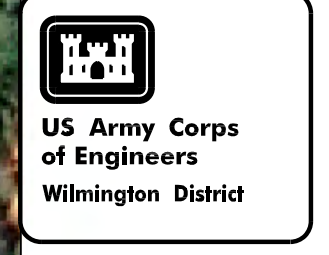
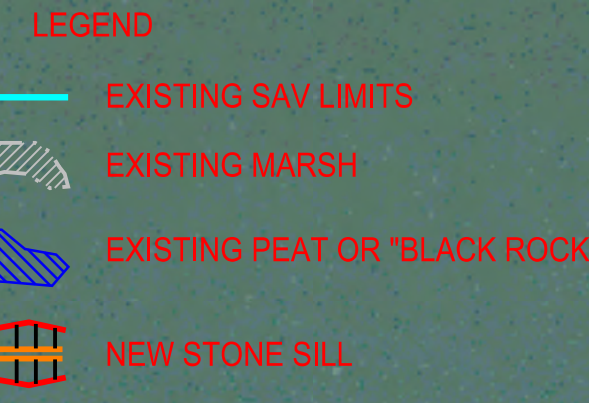

SYMBOL	DESCRIPTION	DATE	APPROVED

DESIGNED BY: LTC	REVIEWED BY: CHIEF DESIGN & GEN ENGR SECTION
DRAWN BY: XXX	DRAWING CODE: H100-05-08
DATE: 9 MAR 2015	FILE NAME: Plan1Revised3.dgn
U.S. ARMY ENGINEER DISTRICT WILMINGTON, NORTH CAROLINA	

NATIONAL PARK SERVICE, CAPE LOOKOUT NATIONAL SEASHORE  
 HARKERS ISLAND SHORELINE STABILIZATION PROJECT  
 CARTERET COUNTY, NORTH CAROLINA

**GENERAL PLAN  
 PROPOSED NORTH STONE SILL**

PLATE NUMBER  
**G-02**



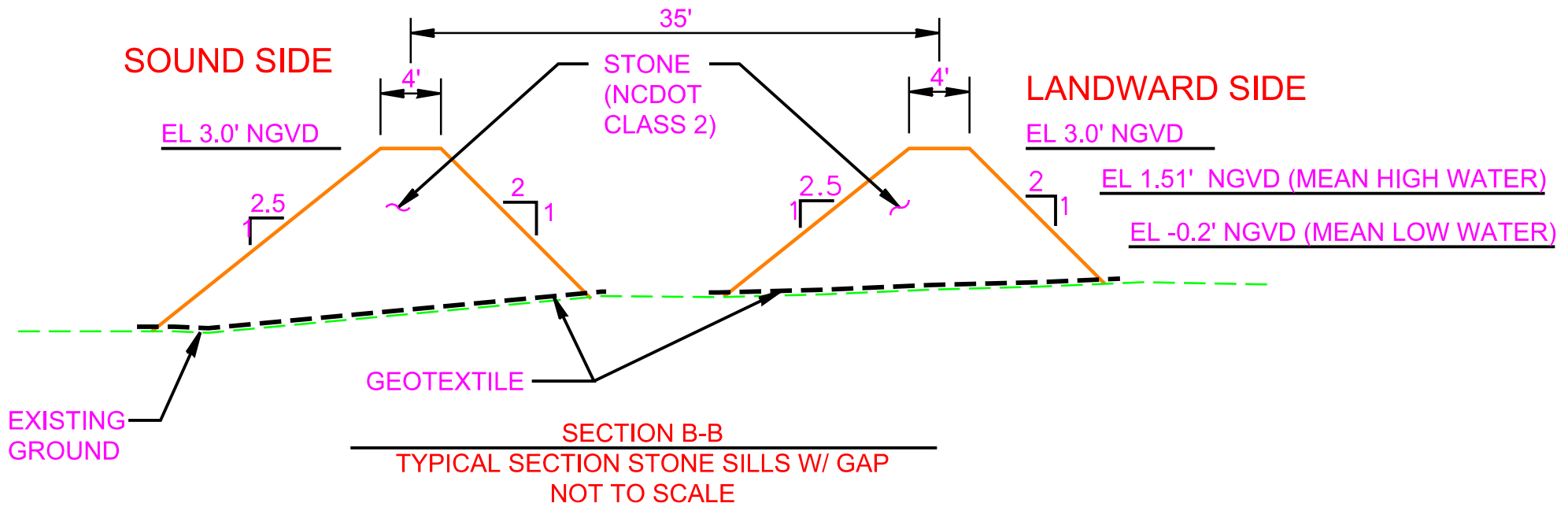
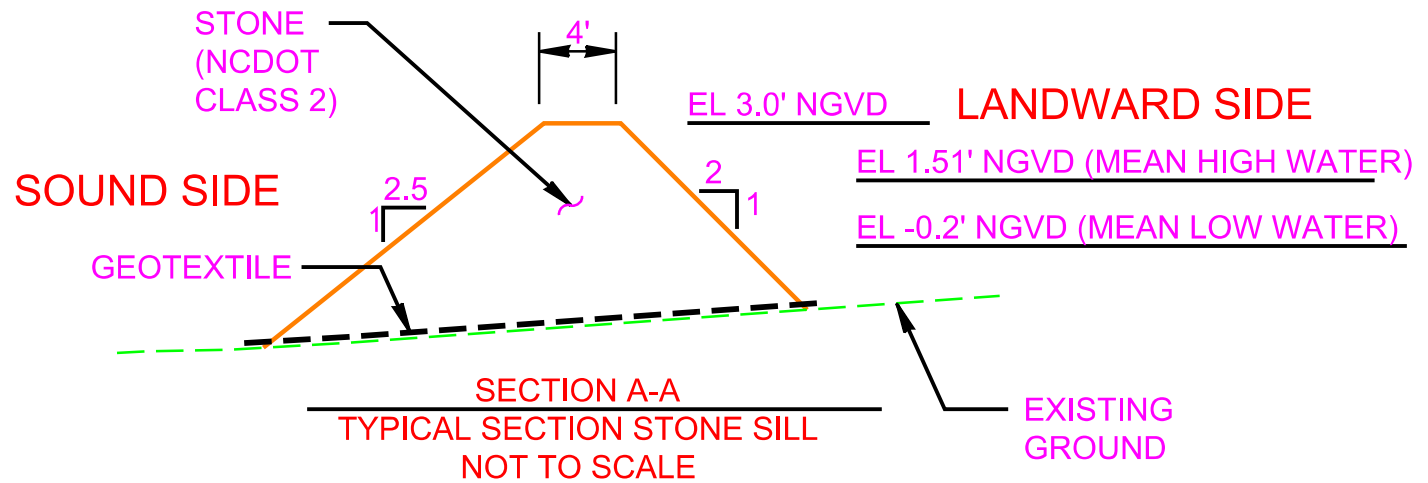



SYMBOL	DESCRIPTION	DATE	APPROVED

DESIGNED BY:	LTC	CHK BY:	XXX	DATE:	9 MAR 2015
REVIEWED BY:	CHIEF DESK & GEN ENGR SECTION	DRAWING CODE:	H100-05-08	FILE NAME:	NorthSillPlan2.dgn
U.S. ARMY ENGINEER DISTRICT CORPS OF ENGINEERS WILMINGTON, NORTH CAROLINA					

NATIONAL PARK SERVICE, CAPE LOOKOUT NATIONAL SEASHORE HARRERS ISLAND SHORELINE STABILIZATION PROJECT CARTERET COUNTY, NORTH CAROLINA	
NORTH SILL LINES 2A, 2C	

PLATE NUMBER	C-01
-----------------	------

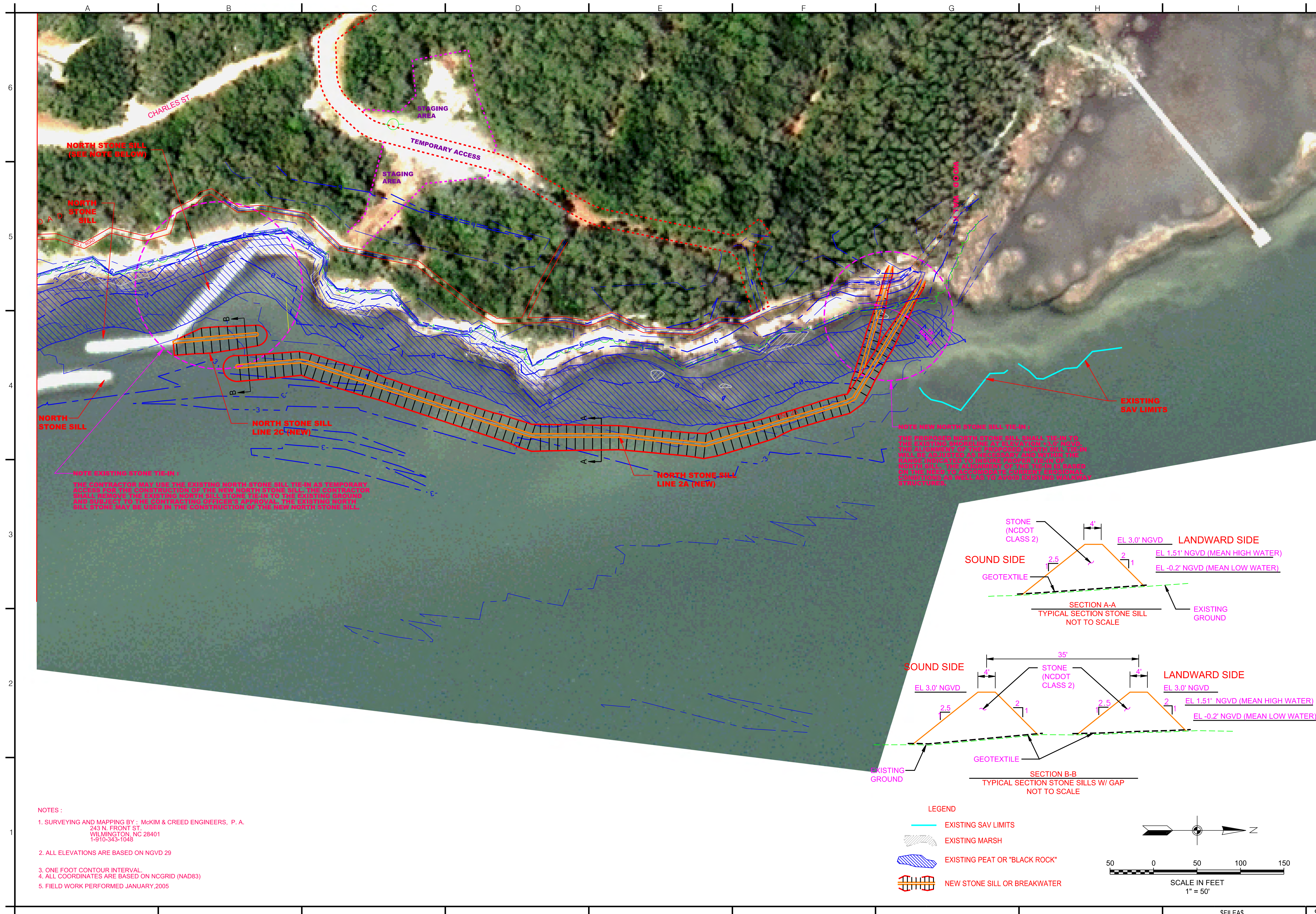

NOTE NEW NORTH STONE SILL TIE-IN:  
THE PROPOSED NORTH STONE SILL SHALL TIE-TO  
THE EXISTING MARSHLINE AT THE EXISTING TIE-IN POINT.  
THE ALIGNMENT OF THE PROPOSED NORTH SILL TIE-IN  
WILL BE ADJUSTED AS NECESSARY AND WITHIN THE  
LIMITS INDICATED BY REDDED CORNER TIE-IN  
POINTS TO THE ALIGNMENT OF THE EXISTING MARSH  
LINE TO ACCOMMODATE CURRENT EXISTENTIAL  
CONDITIONS AS WELL AS TO AVOID EXISTING WALKWAY  
STRUCTURES.

NOTE EXISTING STONE TIE-IN:  
THE CONTRACTOR MAY USE THE EXISTING NORTH STONE SILL TIE-IN AS TEMPORARY  
SCOURING FOR THE CONSTRUCTION OF THE NEW NORTH STONE SILL. THE CONTRACTOR  
SHALL REPAIR THE EXISTING NORTH SILL STONE TIE-IN TO THE EXISTING MARSH  
AND SUBJECT TO THE CONTRACTING OFFICER'S APPROVAL. THE EXISTING NORTH  
SILL STONE MAY BE USED IN THE CONSTRUCTION OF THE NEW NORTH STONE SILL.

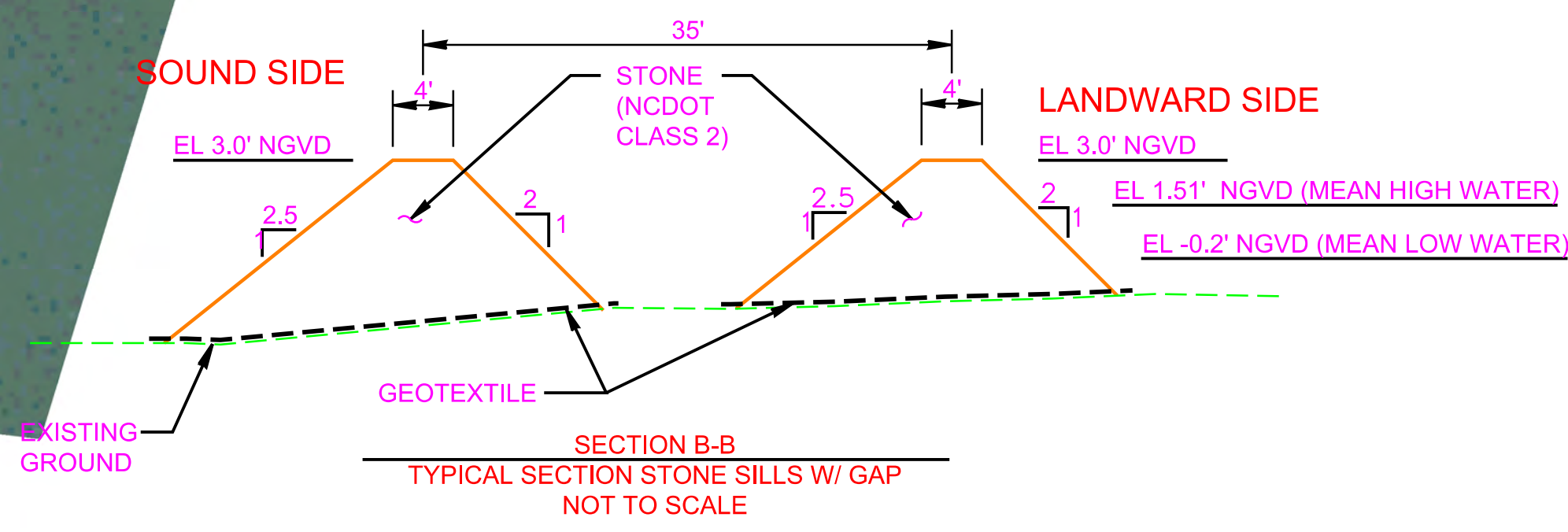
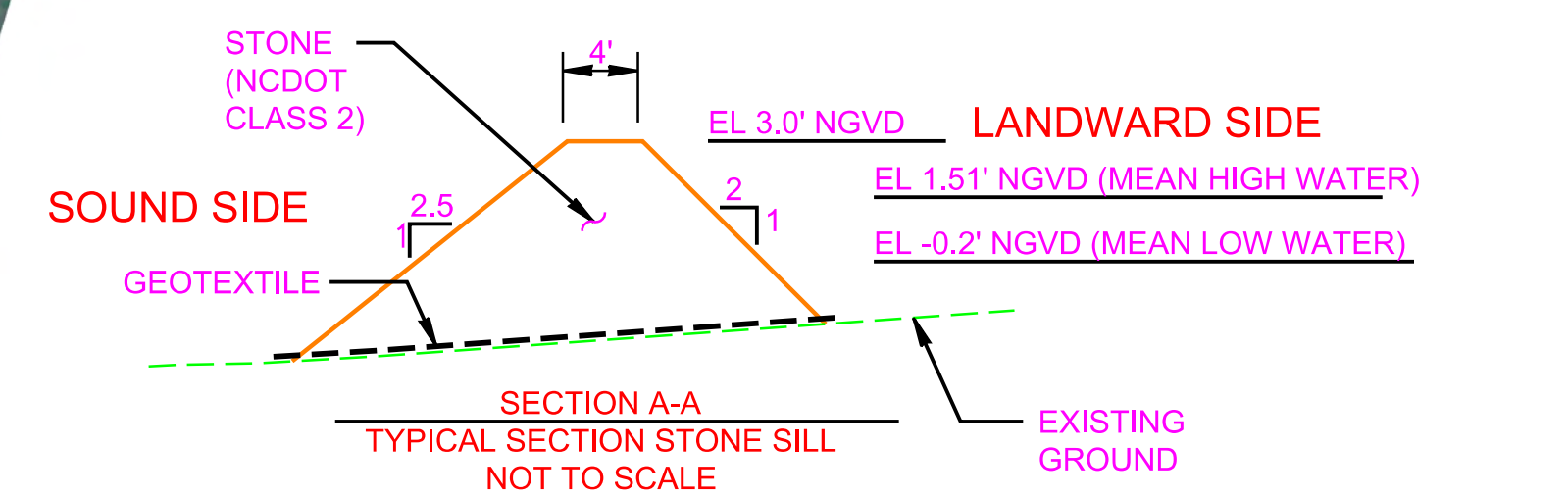

LEGEND

- EXISTING SAV LIMITS
- EXISTING MARSH
- EXISTING PEAT OR "BLACK ROCK"
- NEW STONE SILL OR BREAKWATER

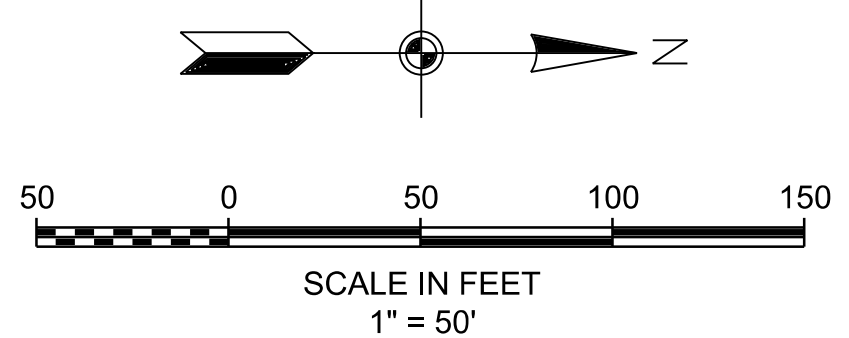

NOTES:

1. SURVEYING AND MAPPING BY : McKIM & CREED ENGINEERS, P. A.  
243 N. FRONT ST.  
WILMINGTON, NC 28401  
1-910-343-1048
2. ALL ELEVATIONS ARE BASED ON NGVD 29
3. ONE FOOT CONTOUR INTERVAL
4. ALL COORDINATES ARE BASED ON NCGRID (NAD83)
5. FIELD WORK PERFORMED JANUARY, 2005